

# Your Complete Industrial Vacuum Source

- Portable • Stationary
- Trailer • Truck



**Multi-Vac**<sup>TM</sup>

**RENT • LEASE • PURCHASE**

[www.multivacinc.com](http://www.multivacinc.com) • 1-800-640-4213

# Multi-Vac Your Complete

## Exclusive Features And Key Benefits

Multi-Vac vacuums are engineered to provide long service life with minimal maintenance attention! Consider these important factors:

- With Multi-Vac units, the dust collector bottom is open to the hopper with no internal baffles or ledges to create bridging and retard the flow of collected material into the hopper. In addition, this greatly reduces the cross contamination when handling different products.
- Multi-Vac is fitted with a positive displacement vacuum pump. As suction increases with increased material flow, Multi-Vac develops only the power required to move the material. The maximum vacuum generated is 16" hg. This is enough to flow material yet remains within the specifications of the vacuum pump manufacturers.
- By using conservative design standards with all our components we have produced a machine which will have a superior operating life span and require minimum maintenance. Consequently a 2 year warranty is furnished with all Multi-Vac Systems.
- Multi-Vac is made completely in our plant in the U.S.A. This allows us greater quality control. In addition, when custom specifications are needed, we are here to work with you.



No matter the need, you are sure to find a Multi-Vac that is perfect for your application.



**Dual Inlets™**

Each Multi-Vac comes standard with Dual Inlets. This feature allows for more flexible machine placement and the added convenience of allowing left or right hand pick-up.

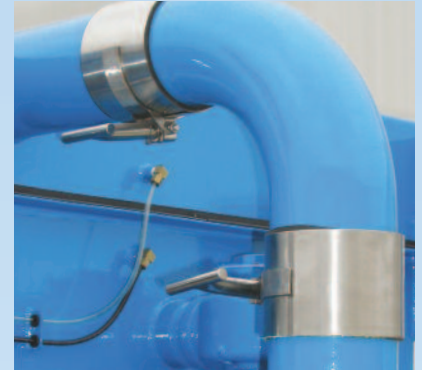

**No Tools Required<sup>SM</sup> Filter/Cage Removal**

When service is required, our **No Tools Required** system provides immediate access to and immediate removal and replacement of filters and cages. These features can save hours over some older designs.



**Super Mini Series**  
Page 6



**Super Mini Series Model FLTP**  
Page 7



**Mini Series**  
Page 8



**Millennium Series**  
Page 9

# Industrial Vacuum Source!

See Page 14 For Optional Accessories



**Multi-Vac  
Bag Filters/Cages**

Multi-Vac Bag Filters have been proven on the widest range of materials from abrasive to high temperature and offer fast replacement. Bag Filters have no pleats to plug or bridge over which is a common problem with more costly cartridges.

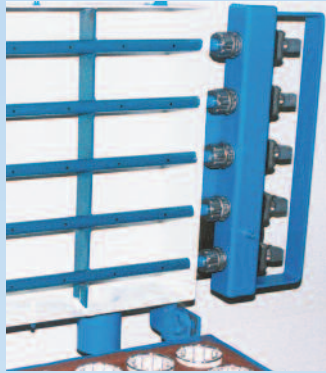

**Reverse Pulse Jet  
Filter Cleaning**

Multi-Vac is equipped with an "on demand" programmable reverse pulse jet filter cleaning system for continuous operation. Multi-Vac also has a manual push-button system for offline filter cleaning.



**Guarded Cam-Roll™  
Air Lift System**

Hopper changing is quick and easy using our Guarded Cam-Roll Air Lift System. The ease of hopper removal keeps downtime to a minimum.



**Built In  
Level Probe**

A built in level probe shuts the unit down whenever the hopper is full. A liquid high level probe is also available as an option when working with liquids.

**Contact Us For More Information Or A Quote**

**Toll-Free 1-800-640-4213 • [www.multivacinc.com](http://www.multivacinc.com)**

21209 Durand Avenue • Union Grove, WI 53182-9711

Tel: 262-878-0366 • Fax: 262-878-0368



**Stationary  
Systems**  
Page 10



**Intercept  
Hoppers**  
Page 11



**Trailer  
Units**  
Page 11



**Conversion Units  
and Upgrades**  
Page 12

## How It Works...

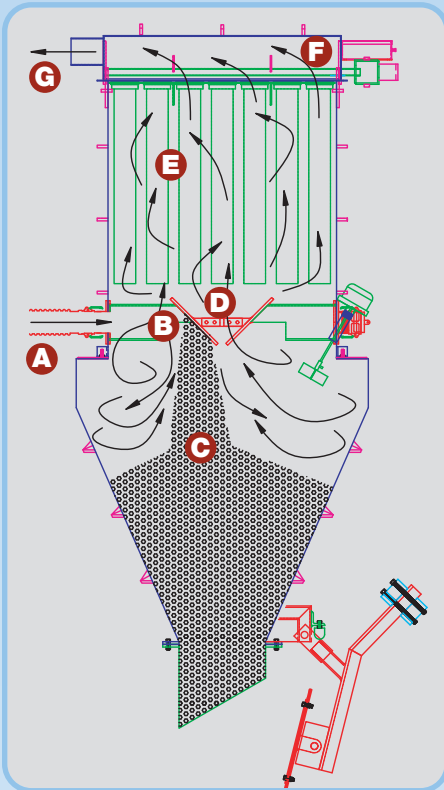

- A.** Material is picked up via a Multi-Vac Air Bleed Nozzle at a nozzle velocity of 4,000 to 7,000 feet per minute based on bulk density of your product.
- B.** The product impacts the abrasion resistant target deflector.
- C.** The heavy product drops from the air stream into the vacuum tight collection hopper.
- D.** Now only dust-laden air travels vertically at a can velocity of approximately 40 to 175 feet per minute. Special attention in this area insures long filter life that will give long vacuum pump life.
- E.** Air born dust is collected on the outside of the filter media.
- F.** The “on demand” programmable reverse pulse jet filter cleaning system ensures continuous operation—the machine does not have to be shutdown for filter cleaning.
- G.** Clean air then passes to the vacuum pump inlet.

The discharge air then passes through a large silencer located in a modular Power Pack.™

## Versatile Use In Multiple Applications

### Stationary Vacuum System Discharging Into A Super Sack

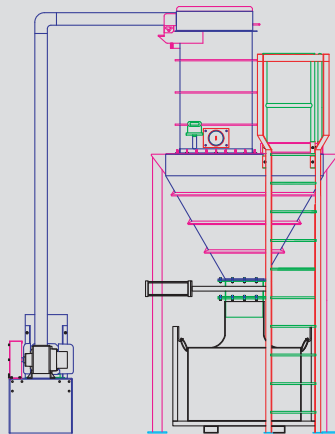

### Fork Lift Truck Portable Vacuum Cleaner

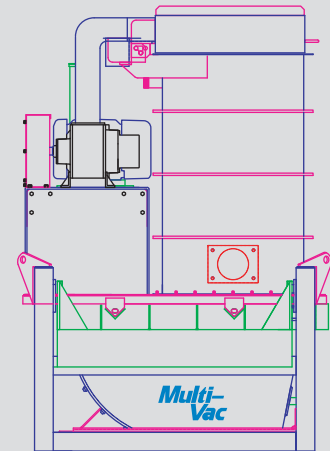

### Stationary Unit With Counter Weight Gate For Batching

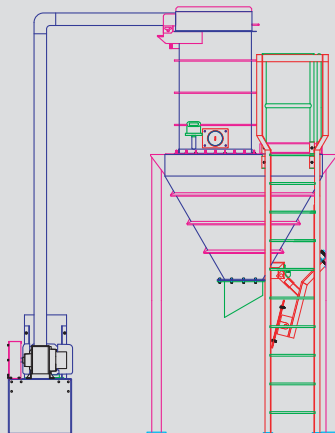

### Stationary Unit With Rotary Air Lock For Continuous Discharge

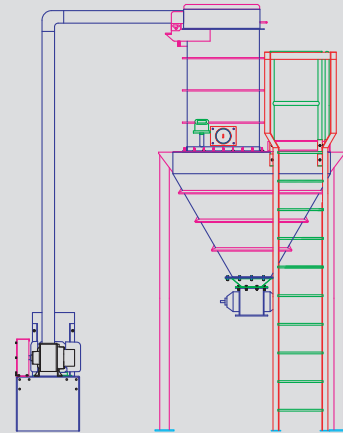

### Stationary Intercept Hopper With Rotary Air Lock

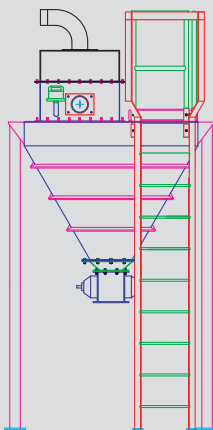

### Fork Lift Truck Portable Intercept Hopper For Loading/Unloading

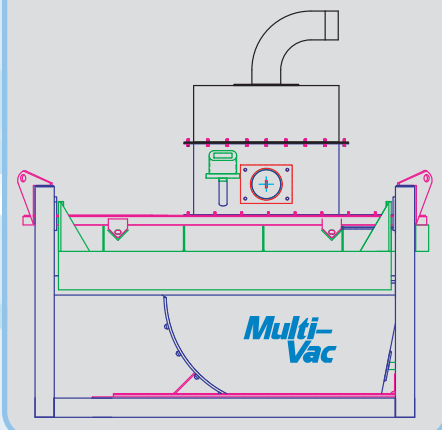

# Engineering and CAD Capabilities

Multi-Vac's engineering and CAD capabilities are the backbone of our Industrial Vacuum Systems. We offer complete design and engineering services. It our engineering staffs' experience that ensures the industrial vacuum systems we develop are state of the art, cost effective, and designed with your specific use in mind. We utilize the latest tools and software including Autodesk, Inventor® 3D CAD and ProNest.

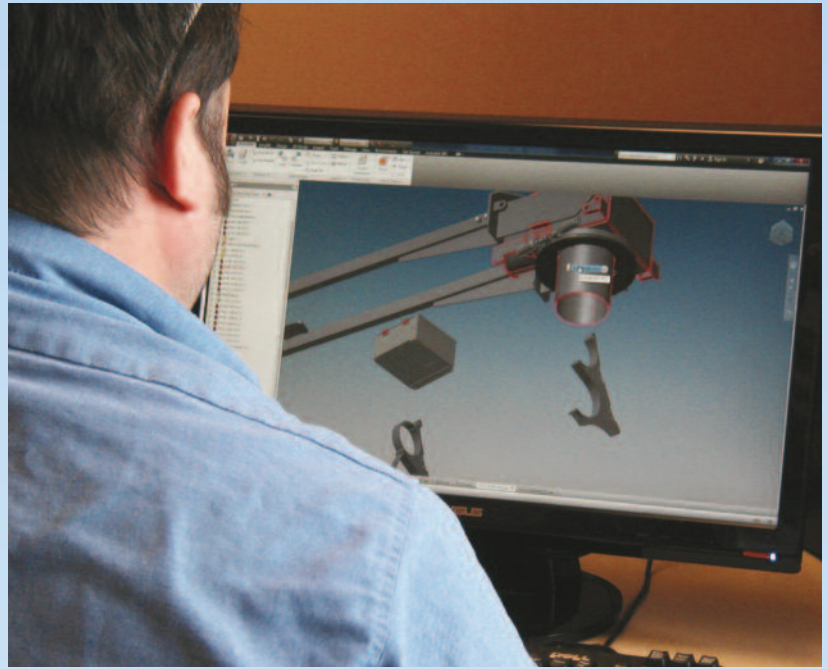

## Discharge Valve Options

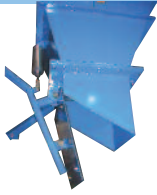

Air Operated Swing Gate mounted on a Bottom Dump Hopper

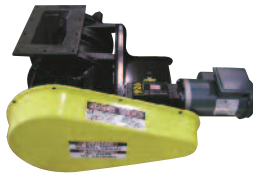

Rotary Airlock, Side Entry, shown just before mounting

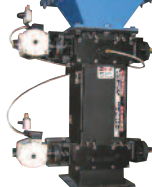

Double Flap Valve mounted on a Bottom Dump Hopper



Orifice Gate shown just before mounting

### Counter Weighted Gate

Standard on our Stationary Vacuum Systems allows batch dumping. As hopper fills, the high level probe senses a full hopper and turns off vacuum, loss of vacuum and weight of product opens gate, once emptied counter-weight closes gate, and vacuum can be restarted.

### Air Operated Swing Gate

Allows batch dumping on stationary vacuum systems, as hopper fills the high level probe will shut down vacuum. Collected material will not be dumped until an operator moves hand lever valve to open swing gate. Once hopper is emptied, operator moves hand lever valve to close gate, vacuum can be restarted.

### Rotary Airlock

Allows continuous dumping on stationary vacuum systems. Material should be rather free flowing and uniform size, so it does not get jammed in the airlock. Maintains a seal on the vacuum side while dumping product on the other side of the airlock.

### Orifice Gate Option

Allows batch dumping on Stationary Vacuum Systems, operation similar to our Air Operated Swing Gate, except it does not require the clearance under the hopper that the swing gate requires. Orifice Gate is ideal for batch loading of Super Sack or Drum Adapter.

### Double Flap Dump Valve

Uses a double flap operation and a small compartment between flaps for continuous dumping. Used for large particle and abrasive material. Flap on vacuum side opens and drops a quantity of product into compartment while unload flap is closed. Vacuum flap closes, then unload flap opens dumping product into container. Unload flap closes and vacuum flap opens dumping next quantity of product into compartment and it keeps cycling this way for continuous operation.

# Multi-Vac Super Mini Series



This compact vacuum loader dumps collected material into a tote box, **not on the floor as competitive machines do.** The Super Mini Series is offered with either positive displacement pump or regenerative vacuum pump.

## Standard Features

- 6 cubic foot dump hopper
- Electric elevation device—hopper dumps into a 34" high tote box
- Cartridge filter with reverse pulse jet cleaning system
- "No Tools Required" Access
- Hopper full shut down probe
- Flip top cartridge access cover
- Dual Inlets, dual inlet deflectors
- Casters

## Optional Features

- Positive Displacement Pump Models
- Regenerative Vacuum Pump Models
- 3/4 Cu.Yd. Air Lift Stand and Self-Dumping Hopper

## Specifications

- Length: 62", Width: 33", Height: 64"
- Shipping Weight: PD Model 1,300 lbs.  
R Model 1,150 lbs.

## Electric Power

- All models available 230/460/3/60, 575/3/60, 380/3/50



## Positive Displacement Pump Models

Model	Horsepower	Air Flow	Hose Size
7.5PD	7.5	180 cfm @ 14" hg	2", 2½", 3"

## Regenerative Vacuum Pump Models

Model	Horsepower	Air Flow	Hose Size
8.5R	8.5	155 cfm @ 9.5" hg	2", 2½", 3"
11.5R	11.5	155 cfm @ 10.5" hg	2", 2½", 3"

# Super Mini Series Fork Lift Truck Portable



This compact vacuum dumps collected material into a 6 cubic foot self-dumping hopper from disposal with a fork lift truck. High performance to convey the heaviest materials.

## Standard Features

- 6 cubic foot self-dumping hopper
- Cartridge filter with reverse pulse jet cleaning system
- “No Tools Required” Access
- Hopper full shut down probe
- Flip top cartridge access cover
- Dual Inlets, dual inlet deflectors

## Optional Features

- 3/4 Cu.Yd. Air Lift Stand and Self-Dumping Hopper

## Specifications

- Length: 46”, Width: 39”, Height: 60”

## Electric Power

- Available 230/460/3/60, 575/3/60, 380/3/50

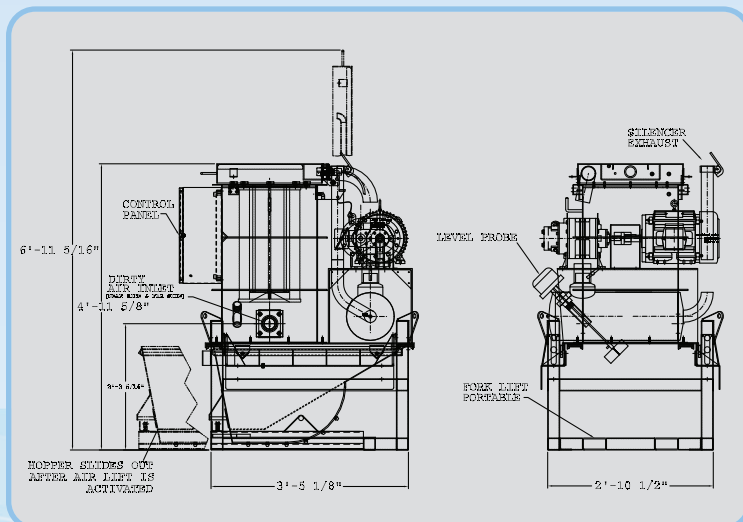

## Positive Displacement Pump Models

Model	HP	Air Flow	Air/Cloth Ratio	Weight
7.5PD	7.5	180 cfm@14" hg	3.5	1,200 lbs
10PD	10	270 cfm@14" hg	3.9	1,300 lbs

## Regenerative Vacuum Pump Models

Model	HP	Air Flow	Air/Cloth Ratio	Weight
8.5R	8.5	155 cfm@9.5" hg	3.0	1,150 lbs
11.5R	11.5	155 cfm@10.5" hg	3.0	1,175 lbs

# Multi-Vac Mini Series



The compact Mini-Series is moveable completely assembled and will fit through an 8' door.

The 3/4 cubic yard hopper means less time travelling to dump material and more time working.

Plus any flowable material can be handled.

## Standard Features

- 3/4 cubic yard hopper
- "No Tools Required" Access
- Positive displacement vacuum pumps are V-belt driven for optimum performance
- Filter bags are reverse pulse jet cleaned on a "on-demand" (programmable) basis
- Hopper full shut down probe
- Flip top filtration access cover
- Dual Inlets, dual inlet deflectors
- Moveable (completely assembled) by a 5,000 lb. fork-lift truck
- No internal baffles or ledges to create bridging and retard the flow of collected material
- Fits thru an 8' high door fully assembled

## Optional Features

- Cartridge filters
- Explosion proof electrics
- LP Gas or Diesel driven vacuum pumps
- Liquids handling probe
- Trailer mounted units
- Interceptor hoppers
- Power Cord Reel
- HEPA filters
- 2 cubic yard hopper

## Stationary Version

- The mini series is also available in a stationary design with a complete range of hopper sizes and discharge configurations.

Can be connected to a manifold or taken to a job.

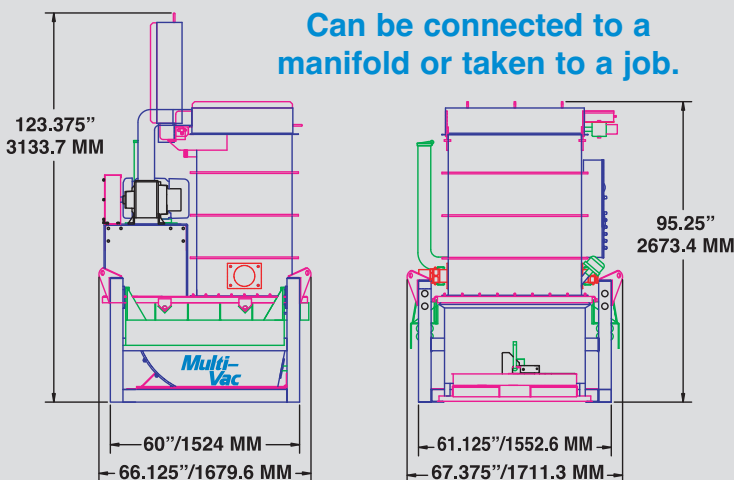

## Multi-Vac Mini Series Models

Model	HP	CFM @ Inches HG	Air/Cloth Ratio	Weight
Mini 1500	15	355@14	3.2	4,000 lbs.
Mini 2000	20	440@16	4.0	4,130 lbs.
Mini 2500	25	600@16	5.3	4,223 lbs.
Mini 3000	30	720@16	6.5	4,300 lbs.



# Multi-Vac Millennium Series

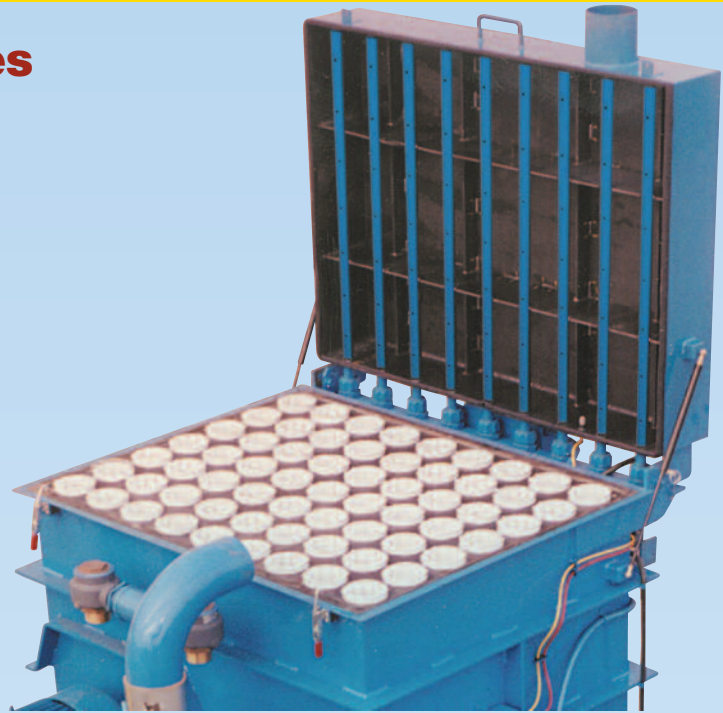

The new generation of vacuum loaders engineered to provide long service life with minimal maintenance attention! With a wide range of capacities available, there is a Multi-Vac Millennium to suit your application.

## Standard Features

- 2 cubic yard hopper
- "No Tools Required" Access  
Positive displacement vacuum pumps are V-belt driven for optimum performance
- Filter bags are reverse pulse jet cleaned on a "on demand" (programmable) basis
- Hopper full shut down probe
- Flip top filtration access cover
- Dual Inlets, dual inlet deflectors
- No internal baffles or ledges to create bridging and retard the flow of collected material
- Movable (completely assembled) by a 8,000 lb. fork-lift truck

## Optional Features

- Cartridge filters
- Explosion proof electrics
- LP Gas or Diesel driven vacuum pumps
- Liquids handling probe
- Trailer mounted units
- Interceptor hoppers
- HEPA filters

## Standard Portable Systems

- Vacuum units are supplied with a 2 cu. yd. fork lift truck type self dumping hopper and a heavy duty air lift stand. A complete range of nozzles, hoses and couplings are available from 2" to 10" in dia.

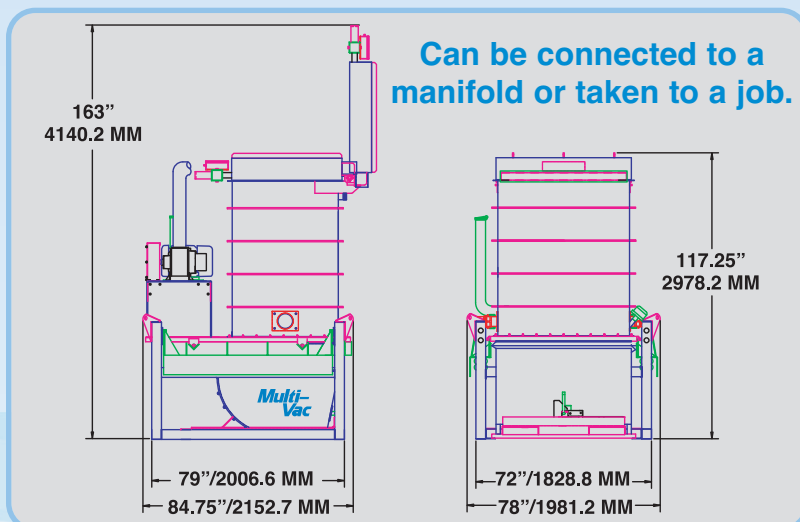

## Multi-Vac Millennium Series Models

Model	HP	CFM 16" HG	Air/Cloth Ratio	Weight
3000	30	720	2.5	6,285 lbs.
4000	40	860	3.0	6,700 lbs.
5000	50	1,250	4.4	6,845 lbs.
7500	75	1,550	5.5	7,430 lbs.

# Stationary Systems and Intercept Hoppers



## Power Packs™

- 10hp to 75hp
- Ease of service
- Electric, Diesel or LP Gas



A Multi-Vac Stationary System can power a manifold system throughout the entire plant. A Multi-Vac Intercept Hopper can be added to the vacuum line to collect reusable material.

## Stationary Systems

A Multi-Vac Stationary System can be used as a central vacuum cleaning system, batching, continuous discharge, loading or unloading.

- On ground controls for easy access
- 16 cubic feet to 5 cubic yard capacities
- “No tools required” filter/cage removal system
- Dual inlets
- Power a manifold system throughout the plant with multiple hose inlet points.

## Intercept Hoppers

A Multi-Vac Intercept Hopper can be used to reclaim picked-up material. Material drops out of the air-stream into the hopper. The remaining dust and fines continue on and are collected at the main unit.

- Stationary or forklift portable
- Can be installed in many configurations
- Hopper full shut down probe
- Standard and custom units available



Stationary System shown with Optional Service Platform

## Stationary Series Models

Model	HP	CFM @ Inches HG	Air/Cloth Ratio
Mini 1000S	10	270@14	2.4
Mini 1500S	15	355@14	3.1
Mini 2000S	20	440@16	3.9
Mini 2500S	25	600@16	5.3
Mini 3000S	30	720@16	6.3
Mini 4000S	40	860@16	5.4
Mini 5000S	50	1,250@16	7.9
Mill. 3000S	30	720@16	2.5
Mill. 4000S	40	860@16	3.0
Mill. 5000S	50	1,250@16	4.4
Mill. 7500S	75	1,550@16	5.5

# Standard and Specialty Trailer Units

DOT  
CERTIFIED  
TRAILERS



Both the Multi-Vac Mini and Millennium Series can be trailer mounted and equipped with electric, LP gas or diesel vacuum pump drives. We also design and build special trailer units for your unique needs.

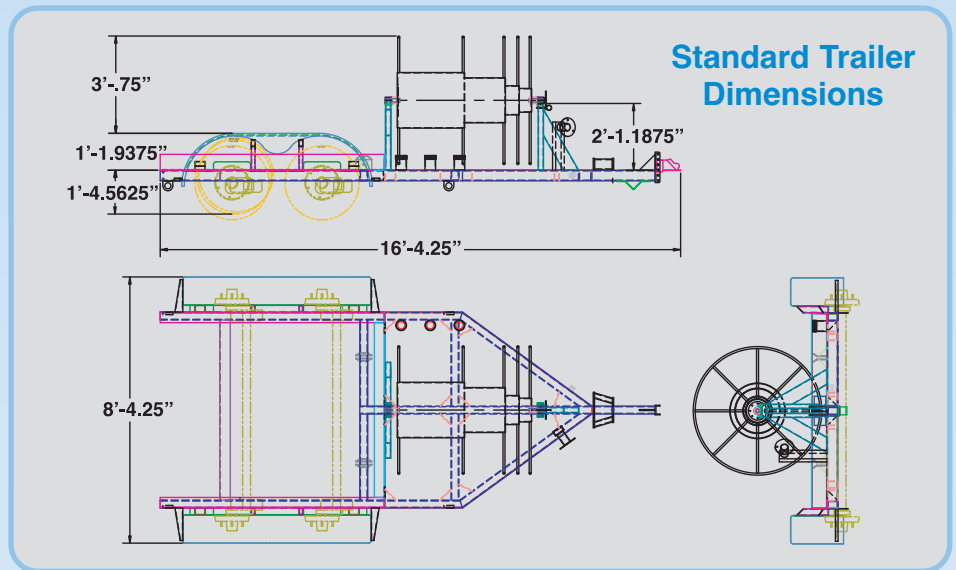

## Standard Features

- See Mini and Millennium Multi-Vac Description for Unit Specifications (pages 8 and 9)
- Trailers can be retrofitted to any of our existing units.

## Optional Features

- Hose Reel
- Nozzle Rack



## Conversions and Upgrades



For approximately half the cost of a new machine, we can replace an old-fashioned bags/cages or expensive cartridges with our “No Tools Required” filters/cages access and removal/ replacement system.

### Save Time and Money

Inspection, removal, and replacement of our filter/cages takes only minutes—not hours as in some other designs.

Conversion of the old machines involves removal of the filter housing and installation of a Multi-Vac filter system complete with reverse pulse valves and a programmable control module.

In addition to the machine cost savings there is also a considerable savings on operating cost.

### The Conversion Process

- 1) Complete disassembly, inspection, sandblasting and replacement or repair of worn and damaged parts.
- 2) Motor testing for correct current draw and speed.
- 3) Vacuum pump inspected and tested at full vacuum.
- 4) New Multi-Vac V-Belt Drive added for maximum performance.
- 5) Control panel is reconfigured to the Multi-Vac system.
- 6) Replacement of gaskets, seals, etc.
- 7) After the re-assembly of the machine, a shop test is performed to ensure maximum performance.
- 8) Final painting is applied after all testing is completed/documented.
- 9) The resulting machine has a “new” appearance as well as a like “new” performance.

### Other Upgrades Offered

- Cartridge to Bag Upgrades
- Vacuum Pump Rebuilding
- Dust Collector Upgrades
- Control System Upgrades
- Conversion to Reverse Pulse Jet Filter Cleaning System

**Do You Have A Tired Shaker Or Expensive Cartridge Vacuum Loader? Ask Us About A Multi-Vac Conversion!**

**Go from this condition to the rebuilt units pictured above.**





For complete information please visit [www.fast-vac.com](http://www.fast-vac.com)

### H-Series™ Hydro Excavator Industrial Vacuum Loaders

These Hydro Excavators have high demand in the oil field industry, well digging applications, municipal utility location and a wide range of other applications. These units offer a safe, effective alternative to traditional digging equipment.

### R-Series and S-Series Industrial Vacuum Loaders

The R-Series and S-Series are heavy-duty, powerful, efficient, and dust free industrial vacuum modules, integrally mounted on a suitable truck chassis for vacuum removal of virtually any dry material, sludges, slurries, and liquids from remote or inaccessible locations. It is easy to maneuver for a one man operation. These heavy duty Industrial vacuum loaders have a wide range of other applications.

### SC-Series™ Self Contained Industrial Vacuum Loader Shuttles

The Fast-Vac™ shuttle is a self-contained heavy duty industrial vacuum loader. This self contained IVL is mounted on a hook lift shuttle module and powered by a diesel engine. This self-contained unit is equipped with a hook lift offloading system for convenient transport on a trailer, chassis or other transport system.

## Industrial Vacuum Loaders

Fast-Vac™ Industrial Vacuum Loaders offers many choices such as H-Series™, S-Series™, R-Series™, or SC-Series™ collector bodies, carbon or stainless steel, rear port hose or boom, truck mounted or drop skid mounted, and a myriad of other options. Simplicity in design and operation with a selection of industry demanded features that improve overall operator efficiency and guarantee easy maintenance.

### H-Series™



### R-Series™



### S-Series™



### SC-Series™

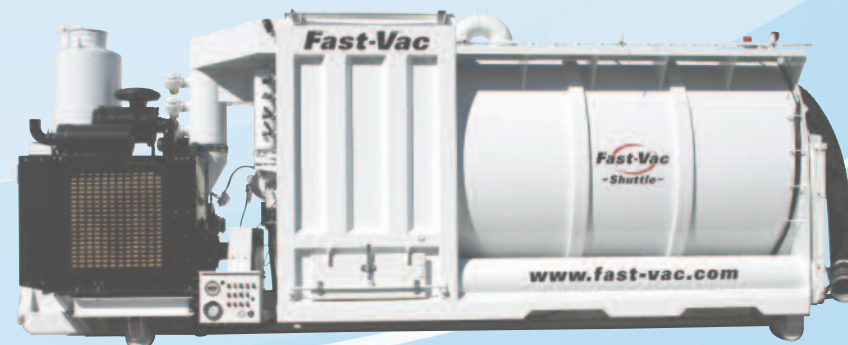

# Accessories



**Nozzles** — A variety of nozzles are available to handle an array of applications and materials.

- A. Flared
- B. Bulk
- C. Round
- D. Flat
- E. 30° Round
- F. 30° Angle Long Round
- G. Flat Nozzle Half Handle
- H. Crevice Nozzle
- I. Round Nozzle with Size Restrictor
- J. Floor Nozzle with Wheels

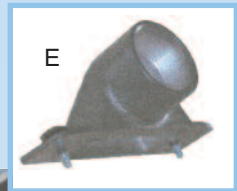

- Brushes**
- A. 6" Hand Brush
  - B. 10" Hand Brush
  - C. Round Brush
  - D. Wall Brush

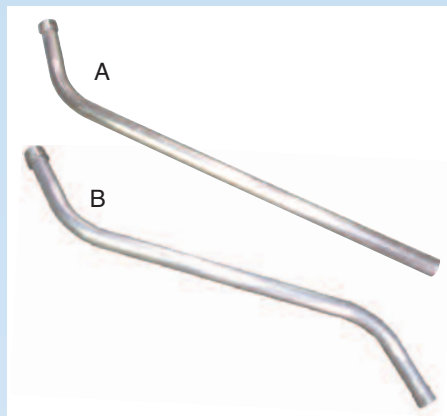

- Rod**
- A. Wall Rod
  - B. Floor Rod

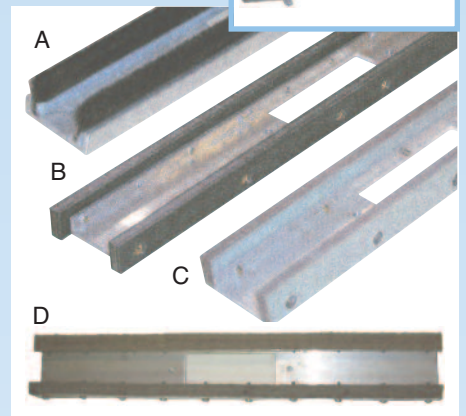

- Adapters**
- A. 2" x 18" Brush
  - B. 2" x 18" Squeegee
  - C. 2" x 18" Fiber
  - D. 2" x 18" Felt
  - E. Master Nozzle
- Note: All adapters require Master Nozzle for mounting.



- Pipe Cleaning Tools**
- A. 4" – 6" Pipe Cleaning Tool
  - B. 6" and Larger Pipe Cleaning Tool

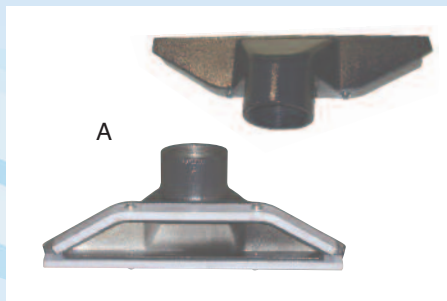

- Gulper Tools**
- A. 2" x 12" Wide Mouth Gulper Tool

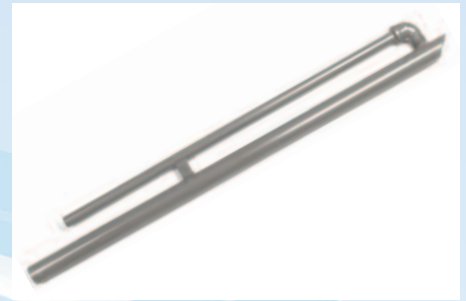

- Bulk Pickup Tool w/Breather**



### Self-Contained Units

When electrical power is not available, Multi-Vac Units can be equipped with LP Gas or Diesel engines with air compressor options.

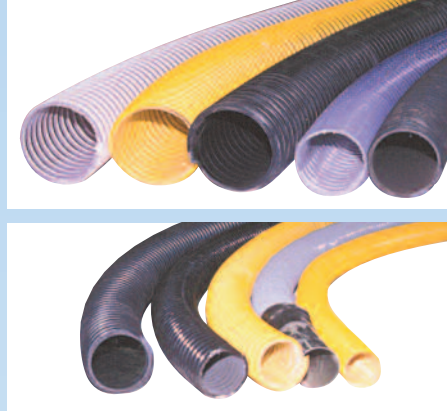

### Hoses and Couplings

A complete range of hoses and couplings are available from 2" to 10" diameter.



### Custom Shovel Tool

Used to shovel gravel, ore or rock into vacuum hose. Features large diameter wheels and operator handle.



### Lift Bale

Lift Bales are available for all Mini and Millennium Series Units. The framework of both Series are designed to be lifted.



### Hoppers

Add additional hoppers to increase operation uptime. Fork-Lift Truck Portable—3/4 yard and 2 yard models.

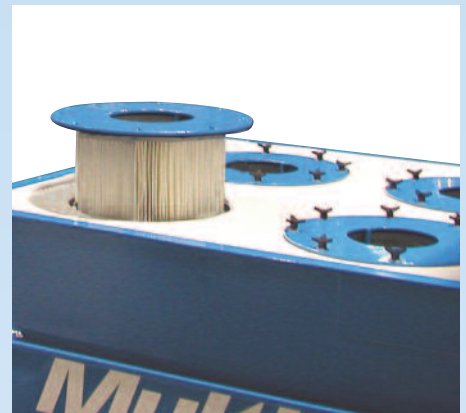

### Cartridges

Upon request, cartridge filters available for special applications.

## Other Optional Features

- Explosion Proof Electrics
- Liquids Handling Probe
- HEPA Filters
- Power Cord Reel
- Trailers can be retrofitted to any of our existing units.
- Interceptor Hoppers

## Custom Units

Custom units up to 300hp can be designed for your specific application. We offer complete design and engineering services.

## Rental Options

Many Models are available for rent on a short or long-term arrangement. Call the Factory for complete details.

## Service

We service what we sell. We carry a complete stock of parts to ensure your Multi-Vac Unit keeps running.

## Warranty



By using conservative design standards with all our components we have produced a machine which will have a superior operating life span and require minimum maintenance. Consequently a 2-year warranty is furnished with all Multi-Vac Systems.

## Industries Served

- Brick Manufacturer
- Foundry
- Steel Manufacturer
- Lime Manufacturer
- Nickel Mine
- Tire Manufacturer
- Pipe Manufacturer
- Tube Manufacturer
- Chemical Manufacturer
- Bakery
- Abrasive Manufacturer
- Copper Mine
- Cement Manufacturer
- Lead Smelter
- Tile Manufacturer
- Window / Door Manufacturer
- Charcoal Manufacturer
- Power Plant
- Chip Board Manufacturer
- Engine Manufacturer
- Insulation Manufacturer
- ReFactory Manufacturer
- Rubber Molder
- Gold Mine

## Materials Handled

- Abrasives
- Alumina
- Aluminum Scrap
- Asbestos
- Ash
- Bark
- Brick
- Carbon Black
- Catalysts
- Cement
- Ceramic Particles
- Cereals
- Chemicals
- Clay
- Clinker
- Coal
- Cullet
- Dust
- Fertilizer
- Flour
- Grains
- Lead Oxide
- Limestone
- Liquids
- Metal Chips
- Mill Scale
- Mineral Wool
- Ore Pellets
- Oxides
- Paper
- Plastic Pellets
- Refractories
- Rocks
- Sand
- Sawdust
- Shot and Grit
- Slag
- Slurries
- Vermiculite
- Wood Chips

## Applications

- All Process Pneumatic Vacuum/Pressure Systems
- General Plant Cleanup
- Material Recovery
- Bin Loading/Unloading
- Central Manifold Systems
- Scaling/Batching
- Spills
- Bulk Loading/Unloading
- Pharmaceutical
- Machining & Milling
- Belt Loading
- Belt Spillage Cleanup
- Dump Truck Loading
- Roof Pea Gravel Removal
- Hazard Cleanup
- Water & Slurry Removal and Recycling
- Low Headroom Mining
- High-Temperature Materials
- Special Engineered Applications
- Plus many more

## Company History

President and Owner, Wally Haag has worked in the Industrial Vacuum Field since 1974. He first started out in the manufacturing area, working his way into Field Service Management, and New Product Development. In 1980, Mr. Haag purchased half ownership of M&W Shops, Inc. (a custom metal fabrication shop) where he continued to use his experience to manufacture New Weldments and Special Vacuum Equipment. In 1990, Mr. Haag took full ownership of M&W Shops. At that time, the decision was made to use his engineering experience of Heavy Vacuum Equipment and Metal Fabricating to design a new mainte-

nance friendly product line of Vacuum Cleaners, Loaders and Conveyors which is now Multi-Vac. Since that time, Multi-Vac has become a well known and respected name in steel mills, foundries, cement and brick plants as well as in the mining, plastic, rubber and chemical industries. Successful installations are in use from the East Coast to the West Coast, South America, Canada, Mexico Israel, Korea, China and Thailand.

In 2011, Fast-Vac™ product line of vacuum trucks was purchased. To learn more, visit [www.fast-vac.com](http://www.fast-vac.com)

# Multi-Vac™

Multi-Vac™ — A Division of M & W Shops, Inc.

21209 Durand Avenue • Union Grove, WI 53182-9711

Tel: 262-878-0366 • Toll-Free: 1-800-640-4213 • Fax: 262-878-0368

[www.multivacinc.com](http://www.multivacinc.com)

**RENT • LEASE • PURCHASE**